

Automated Upper Dipper by Sensing Light Intensity: Implementation

Chandani raut ,Komal Dhok ,Sumit Chandwani ,Parul Jha

Department of Computer science Engineering, Jhulelal Institute of Technology, Nagpur,India

Department of Computer science Engineering, Jhulelal Institute of Technology, Nagpur,India

Department of Computer science Engineering, Jhulelal Institute of Technology, Nagpur,India

Department of Computer science Engineering, Jhulelal Institute of Technology, Nagpur,India

Abstract: Today, one of the biggest problems Vehicle drivers in India are facing during night is the temporary loss of vision due to the Upper beam (high beam) coming from the Vehicle in the opposite direction. Moreover, the victims of this problem are mostly the students who are the backbone of their families. We have decided to undertake this project especially because this problem has become more dominant in recent years. Over five lakh accidents take place in the country annually, out of which, 41% (Approx. 2 Lakh) are due to road mishaps during night, and 18% (Approx. 90,000) are due to the vehicle headlight glare. In the current scenario, most of the automobile manufacturers in India have zeroed in on the Mass Production of their cars in order to fulfill their economic and financial goals without considering the accidental factors arising from the situation mentioned above. Automobile manufacturers like BMW, Skoda, Audi, Mercedes (and more) have provided facilities like intelligent headlight technology in their car models, which act as a remedy to this problem by reducing accidents by 60-70%. But these are only limited to their high end models (> 20 lakh and so on) due to which there arises a question for the middle class buyers about road safety. This project is targeted to facilitate such buyers so that they also can follow the protocol of Road Safety. Currently there is no provision for switching the headlight beam of the vehicle, automatically in mid-range vehicles. The Central Motor Vehicles Rules 1989 and Central Motor Vehicles Act, 1988, have chalked out certain Protocols related to the situation mentioned above. Operated by the Synergy of a Microcontroller and a Sensor, this device is capable of automatically shifting the Upper beam of the vehicle coming from the opposite direction, to the dipper beam, thus eradicating the problem of vision loss and avoiding accidents due to it. In the following sections we define the principle and design of the "Automatic Headlight Beam Shifter" device.

Keywords: LDR, Microcontroller,LED

I. Introduction

With the enormous advancement in the field of science and technology everyone is enjoying there luxurious life in 21st century. Due to this day by day number of vehicles are increasing as well as accidents are increasing. Most of the accidents are happened in night due to glaring effect to eyes due to upper mode of headlight of upcoming vehicle. To overcome this glaring effect an average human eye needs 3 to 8 sec which may be one of reason for accidents. the high beam of headlight which causes glaring effect on driver eye and if on that time vehicle speed is more than 60km/hr causes the vehicle goes out of road or strikes on upcoming vehicle. there is an arrangement for upper dipper connection as per circuit diagram they shown so the dipper beam cannot be able ON they demonstrate using LED's for upper and dipper beam here no actually headlight beam is used. To overcome these problems .

Road accidents occur every day with the higher percentage of occurrences at night. This is because visibility at night is not as good as that at the day time. The importance of bright driving lights to a vehicle has as much an opposite effect on the opposing vehicle, hence the need to reduce that effect . Drivers are human and tend to forget to switch the beams ,which is task that has to be done over and over .and this can be tiring.when our eyes are exposed to a very bright source of light,around 1000 lumens, we experience a glare.This glare is produced due to over exposure of the road and cones inside our eye.Even after the source of glare is removed, an after-image remains in our eye that creates a blind spot.This phenomenon is called the troxler effect .

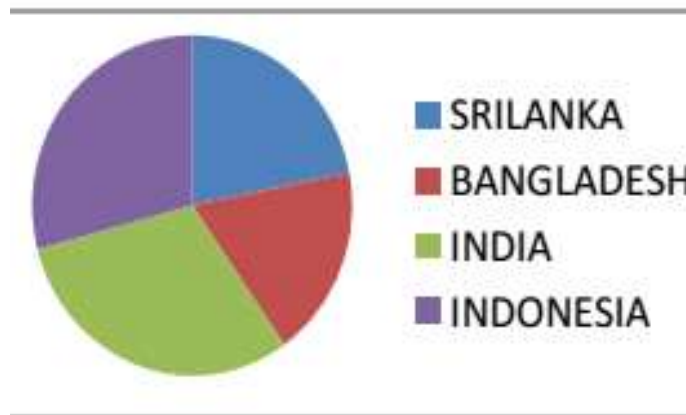

Fig: accident due to troxler effect

II. Related Work

2.1 AUTOMATIC UPPER DIPPER FOR VEHICLE

While driving a car in night a problem like many drivers do not dip the headlamps of their vehicles in night while approaching. The switching operation is used to dip the head light which may distract the concentration. Automatic upper dipper is the latest convenience in today's cars. This eliminate the need for the driver to manually switch on or switch off the dipper beam in most driving situations. The automatic upper dipper system reacts like the human eye to headlight of incoming vehicles and independently turns upper beam to dipper beam when needed. Such a system offers both safety and convenience.

CIRCUIT DIAGRAM:

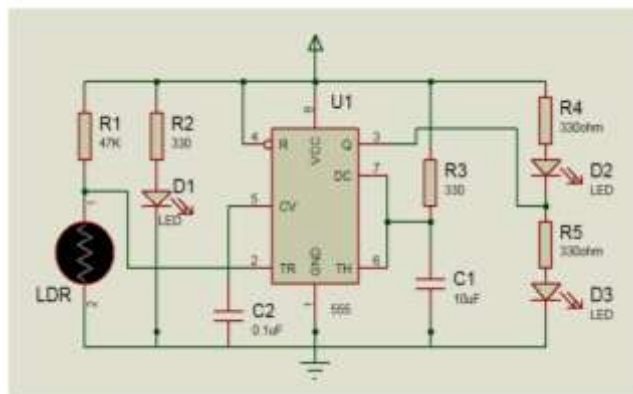

2.2 Automatic Dipper for Vehicles

While driving a car in night a problem like many drivers do not dip the head lamps of their vehicles in night while approaching. The several switching operation is used to dip the head light which may distract the concentration. To overcome this type of problem the innovative group Dreamlover Technology designs a unique electronics gadget called “Automatic Dipper” using very popular IC NE555 and LDR.

Circuit Description

The entire circuit of automatic dipper consist LDR followed by timer IC NE555 (IC_1) and few other components, where LDR is used as sensor. LDR sense the light and change its internal resistance according light fall on it, which is further mounted in PVC pipe of 4 cm length positioned on the grill of car or in front such that the light fall on the LDR only when vehicles is approaching and is distance of 3M to 9M. When light fall on it the resistance decrease and makes output of IC_1 low which energized the relay. The relay operates and voltage across the head lamps is reduced. When the distance between two approaching vehicles is more than 9 meter or less than 3 meter the circuit is not operated.

2.3 Automatic Dipper for Vehicles

While driving a car in night a problem like many drivers do not dip the head lamps of their vehicles in night while approaching. The several switching operation is used to dip the head light which may distract the concentration. To overcome this type of problem the innovative group Dreamlover Technology designs a unique electronics gadget called “Automatic Dipper” using very popular IC NE555 and LDR.

Circuit Description

The entire circuit of automatic dipper consist LDR followed by timer IC NE555 (IC₁) and few other components, where LDR is used as sensor. LDR sense the light and change its internal resistance according light fall on it, which is further mounted in PVC pipe of 4 cm length positioned on the grill of car or in front such that the light fall on the LDR only when vehicles is approaching and is distance of 3M to 9M. When light fall on it the resistance decrease and makes output of IC₁ low which energized the relay. The relay operates and voltage across the head lamps is reduced. When the distance between two approaching vehicles is more than 9 meter or less than 3 meter the circuit is not operated.

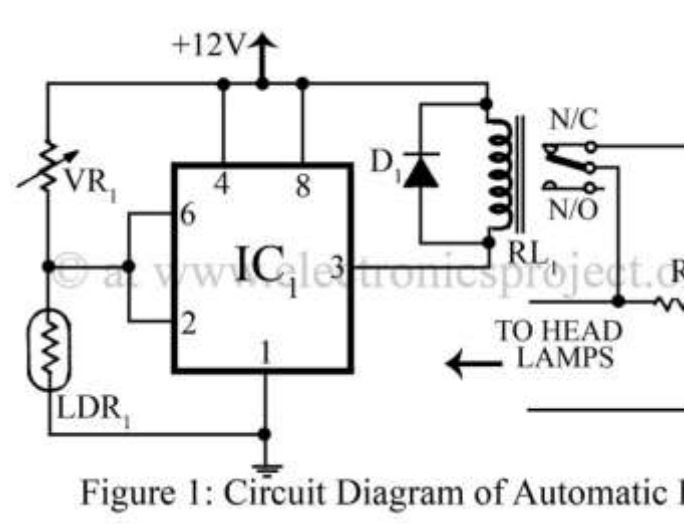

Figure 1: Circuit Diagram of Automatic I

2.4 DESIGN AND IMPLEMENTATION OF AUTOMATIC HEADLIGHT DIMMER FOR VEHICLES USING LIGHT DEPENDENT RESISTOR (LDR) SENSOR

Light is electromagnetic radiation within a certain portion of the electromagnetic spectrum. The word usually refers to visible light, which is visible to the human eye and it is responsible for the sense of sight. Visible light is usually defined as having wavelengths in the range of 400–700 nanometers (nm), or 400×10^{-9} m to 700×10^{-9} m, between the infrared (with longer wavelengths) and the ultraviolet (with shorter wavelengths). Light can be produced by nature or by humans. "Artificial" light is typically produced by lighting systems that transform electrical energy into light. The human eye is a very sensitive organ. It works almost an entire day without any rest. The human eyes are adaptable to a particular range of vision. There are two visions namely the scotopic and photopic vision. Human eyes actually behave differently in different conditions. During bright surroundings, our eyes can resist up to 3 cd/m². This is the photopic vision. During dark and unlit conditions, our eye switches to scotopic vision which has a range of 30-45 μ cd/m². It takes 4 seconds for our eyes to change from photopic vision to scotopic vision. This is also an example of Troxler effect [1]. As the brightness increases, the strain to focus on an object increases. This will increase the response time of that person. The requirement of headlight is very common during night travel. The same headlight which assists the driver for better vision during night travel is also responsible for many accidents that are being caused. The driver has the control of the headlight which can be switched from high beam (bright) to low beam (dim). The headlight has to be adjusted according to the light requirement by the driver [2]. During pitch black conditions where there are no other sources of light, high beam is used. In all other cases, low beam is preferred. But in a twoway traffic, there are vehicles plying on both sides of the road. So when the bright light from the headlight of a vehicle coming from the opposite direction falls on a person, it glares him for a certain amount of time. This causes disorientation to that driver. This discomfort will result in involuntary closing of the driver's eyes

momentarily. This fraction of distraction is the prime cause of many road accidents [3]. The prototype that has been designed to reduce this problem by actually dimming down the bright headlight of our vehicle to low beam automatically when it senses a vehicle at close proximity approaching from the other direction. The entire working of the dimmer is a simple electronic circuitry arrangement which senses and switches the headlight according to the conditions required

III. Problem Statment

Road accidents occur every day with the higher percentage of occurrences at night. This is because visibility at night is not as good as that at the day time. The importance of bright driving lights to a vehicle has as much an opposite effect on the opposing vehicle, hence the need to reduce that effect . Drivers are human and tend to forget to switch the beams ,which is task that has to be done over and over .and this can be tiring.when our eyes are exposed to a very bright source of light,around 1000 lumens, we experience a glare.This glare is produced due to over exposure of the road and cones inside our eye.Even after the source of glare is removed, an after-image remains in our eye that creates a blind spot.This phenomenon is called the troxler effect . the troxler effect increases driver reaction time by up to 1.4 seconds. This means that when traveling at 100km/h, it would take the driver 37.5 meters to see and react to road is hazards

IV. Proposed System

1. OVERVIEW OF LIGHT DEPENDENT RESISTOR (LDR)

Light Dependent Resistor (LDR) is a type of semiconductor and its conductivity changes with proportional change in the intensity of light. A light dependent resistor (LDR) is a resistor whose resistance decreases with increasing incident light intensity; thus , it exhibits photoconductivity. Light Dependent Resistors are very useful especially in light/dark sensor circuits. Normally the resistance of an LDR is very high, sometimes as high as 1000 000 ohms, but when they are illuminated with light resistance drops dramatically. A Light Dependent Resistor is made of a high resistance semiconductor. If light falling on the device is of high enough frequency, photons absorbed by the semiconductor give bound electrons enough energy to jump into the conduction band. The resulting free electron and its hole partner conduct electricity, thereby lowering resistance. The light sensitive part of the LDR is a wavy track of Cadmium Sulphide. Cadmium Sulphide cells rely on the materials ability to vary its resistance according to the amount of light striking the cell. The figure below shows the Construction of LDR.

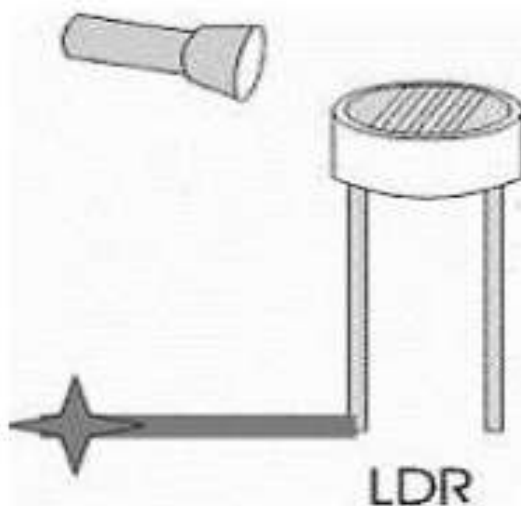

Fig.5. Construction of LDR

2.CONNECTION OF MICROCONTROLLER

The microcontroller based on automatic dipper circuit using 89S52 mc, where 9v battery supply is given to the 7805 regulator which gives 5v constant to the op-amp i.e. lm358, when LDR sensed the light the op-amp convert analog signal to digital signal, the output of lm358 is connected to AT89S52 where program

was goes on, that output of microcontroller trun on the switches andthe N/O contact of the relay which gives the dipper light. A. Microcontroller: This is the brain of our project CPU (central processing unit).

AT89S52 is a slightly more powerful microcontroller which provides highly flexible and cost effective solutions to many embedded control applications. Its features include the following: 1. It has 128 bytes of internal RAM. 2. It has low power; high performance CMOS 8- bit microcomputers with 8K bytes of flash programmable and erasable read only memory (PEROM). 3. Fully static operation: 0 Hz to 24 M Hz. 4. It has 8 programmable I/O lines i.e. it has 4 ports (port0 to port3) with 8 lines each. 5. A third 16-bit Timer/counter is present inside this microcontroller to strengthen its operation, compared to only 2 timers in standard 8051. 6. It has eight interrupted sources7.One more additional feature of AT89C52 is that it has 26 special function registers, 5 more than the standard 8051. 8. The device is manufactured using ATMEL’s high-density nonvolatile memory technology and it is compatible with the industry-standard 80C51 and 80C52 instruction set and pin out.

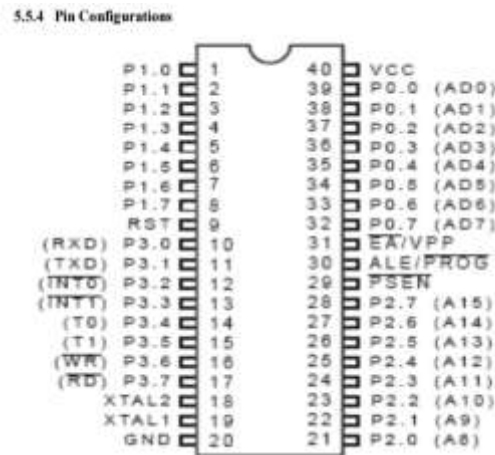

Fig: microcontroller

3. HEADLIGHT OF VEHICLE :

Headlamp at high beam intensity In every vehicle dipper beam is provided in addition with the upper beam to reduce the dazzle from oncoming vehicle. Automatic dipper light control is a system which automatically changes the headlight from upper to dipper beam by sensing the headlight of oncoming vehicle



V. Flow Diagram

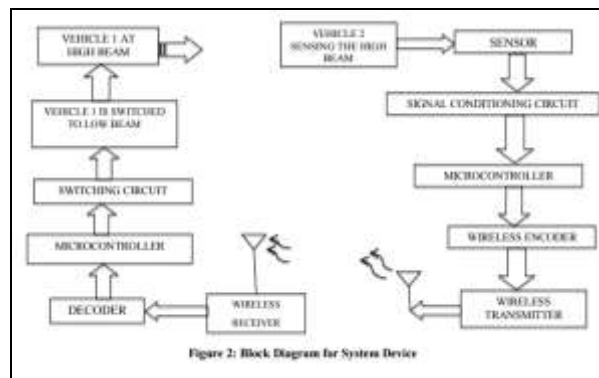

Figure 2: Block Diagram for System Device

VI. Implementation

In designing the block diagram, the software had menu that contains various figures. Rectangular and square boxes were chosen to represent the various components used for the prototype.

1. The vehicle 2 senses the high beam of vehicle 1 with the help of the Light Dependent Resistor (LDR) sensors and converts the light intensity into electrical signal and send it to the signal conditioner or Analog to Digital Converter (ADC).
2. The ADC converts the analog signal at it input into digital signal for the microcontroller to work with.
3. The Microcontroller block functions as the main control unit which will monito the data from ADC and operates the Zigbee Transceiver & relay when the sensing values go beyond the set point.



Fig: In Day time



Fig:In Night time

In this project there are two sensor module is used one sensor module is used to sense the light during day and night.

And another sensor module is used for sensing the oncoming vehicle. The IR sensor module consist of mainly of the IR transmitter and receiver, Opamp, variable resistor (trimmer port), output LED in brief. the microcontroller is the brain of our project CPU (central processing unit). The microcontroller based on automatic dipper circuit using 89S52 mc, where 9v battery supply is given to the 7805 regulator which gives 5v constant to the op-amp i.e. lm358, when LDR sensed the light the op-amp convert analog signal to digital signal, the output of lm358 is connected to AT89S52 where program was goes on, that output of microcontroller trun on the switches and the N/O contact of the relay which gives the upper dipper light.

IR LED Transmitter

IR LED emits light, in the range of infrared frequency. IR light is invisible to us as its wavelength (700nm-1mm) is much higher than the visible light range. IR LEDs have light emitting angle of approx. 20-60 degree and range of approx few centimeters to several feet, it depends upon the type of IR transmitter and the manufacturer.

Some transmitters have the range in kilometers. IR LED white or transparent in colour, so it can give out amount of maximum light.

Photodiode Receiver

Photodiode acts as the IR receiver as it conducts when light falls on it. Photodiode is a semiconductor which has a P-N junction, operated in Reverse direction when light falls on it, and the amount of current flow is proportional to the amount of light. This property makes it useful for IR detection. Photodiode looks like a LED, with a black colour coating on its outer side, black colour absorbs the highest amount of light.

LM358 Opamp

LM358 is an Operational Amplifier (Op-Amp) is used as a voltage comparator in the IR sensor, the comparator will compare the threshold voltage set using the preset (pin2) and the photodiode's series resistor voltage (pin3).

Photodiode's series resistor voltage drop > Threshold voltage = Opamp output is high

Photodiode's series resistor voltage drop < Threshold voltage = Opamp output is low

When Opamp's output is high the LED at the Opamp output terminal turns on (indicating the direction of object).

Variable resistor

The variable resistor used here is a preset. It is used to calibrate the distance range at which object should be detected.

How to use IR sensor module

The 5VDC supply input is given to the VCC pin and the supply negative is connected to the GND terminal of the module. When no object is detected within the range of the IR receiver, the output LED remains off.

When an object is detected within the range of the IR sensor the LED glows.

VII. Conclusion

The Automatic upper dipper can perform a great deal in reducing the manual efforts and fatigue of drivers in dipping the headlamp frequently while driving through highway full of moving vehicles. This is very much helpful and useful to the person who drives during night time. Newer and better technologies always come with time and it will help in reducing the manual labour and difficulties in the sector where it is made use. In short it is a device with bright future. Like for example the people who come back home from their workplace after the sun sets. And when the highway will be full of vehicles, trucks, buses and even the two-wheelers. Our project is made for the safety of the people around. Thus implementation of this device in every vehicle in future will not only avoid accidents but also provide a safe and a comfortable driving.

VIII. Future Enhancement

In future we can use this technology for heavy vehicles such as trucks, buses, etc

References

- [1]. Tejas Vijay Narkar, "AUTOMATIC DIPPER LIGHT CONTROL FOR VEHICLES", IJRET pISSN: 2321-7308
- [2]. Udaya Sharma 1, Deepak Rasaily 2, Tashi Rapden Wangchuk, 3 Ankita Pradhan 4 Kiratti Upashna, "Automatic Dipper Circuit for Vehicle using AT89S52 Microcontroller" IJETT – Volume 33 Number 8- March 2016
- [3]. www.autodipper.com/concept.html/
- [4]. www.electronicproject.org/automatic-dipper-for-vehicles/ [5] http://en.wikipedia.org/wiki/555_timer_IC/
- [5]. <https://en.wikipedia.org/wiki/Photoresistor>
- [6]. <https://learn.sparkfun.com/tutorials/switch-basics/switch-basics/switch-basics/switch-basics>
- [7]. D. Roy Choudhary, "Linear Integrated Circuits", 4th ed. New Age International Publishers, p 311-315
- [8]. Sushil Kumar Choudhary, Rajiv Suman, Sonali Honey Banga "ELECTRONIC HEAD LAMP GLARE MANAGEMENT SYSTEM FOR AUTOMOBILE APPLICATION", IJRAT-vol.2, No.5, May 2014 E-ISSN:2321-9637
- [9]. G.M. Pushpanjali, P.S. Mali, R.R. Naman "AUTOMATIC HEADLIGHT DIPPER WITH RESPECT TO UPCOMING VEHICLES RESPONSE", IJET (Special issue on ICRIET-2016) 7(2):169-172(2016)